

Type SLB Load Cell



Flintec load cells are designed to meet the most stringent accuracy requirements. Certifications have been obtained from Weights & Measures Authorities, worldwide.

SLB load cells are available in the capacities 200 lb to 5000 lb (91 kg to 2268 kg) and include Accuracy Classifications GP, C1 and C3 according to OIML R 60; NTEP 5000 d.

They offer stainless steel construction and improved potting, making them suitable for use in tough industrial environments.

The unique “blind” loading hole combined with the available Flintec loading hardware provides an excellent price-performance ratio.

It allows very low profile platform design and offers advantages in all kinds of weighing applications.

A version with loading hole counter bore M12 is available as well.

The Flintec calibration technique (in mV/V/Ω) eliminates time consuming corner calibration in multiple load cell systems.

Important Features

- Capacities: 200 lb to 5000 lb.
- High accuracy.
- Stainless steel construction.
- Protection IP 67.
- Low profile.
- High input resistance: 1100 Ω.
- W&M certified for 3000 intervals.
- Unique “blind” loading hole.
- Calibration in mV/V/Ω.
- Complete range of loading hardware available.
- Factory mutual approved.

Option

- Explosion proof EEx ia IIC T6...T4.

SLB Specifications

Maximum capacity (=E _{max})	lb	200 / 500 / 1000 / 2500 / 5000	
Metric equivalents (1 lb=0.45359 kg)	kg	91 / 227 / 454 / 1134 / 2268	
Rated Output (=RO)	mV/V	2 ± 0.1%	
Calibration in mV/V/Ω (A...I classified)	%RO	≤ ± 0.05 (≤ ± 0.005)	
Accuracy class according to OIML R 60		(GP)	C3
Maximum number of verification intervals (n)		n.a.	3000
Minimum load cell verification interval (v _{min})		n.a.	E _{max} /11500
Combined error	%RO	≤ ± 0.040	≤ ± 0.020
Creep error (30 minutes)	%RO	≤ ± 0.060	≤ ± 0.024
Temperature effect on minimum dead load output	%RO/°C	≤ ± 0.0040	≤ ± 0.0011
Temperature effect on sensitivity	%/°C	≤ ± 0.0020	≤ ± 0.0011
Excitation voltage	V	5...15	
Zero balance	%RO	≤ ± 1.0	
Input resistance	Ω	1106 ± 5	
Output resistance	Ω	1000 ± 1	
Insulation resistance	MΩ	≥ 5000	
Compensated temperature range	°C	-10...+40	
Operating temperature range	°C	-20...+65	
Safe load limit	%E _{max}	200	
Ultimate load	%E _{max}	300	
Safe side load	%E _{max}	100	
Load cell material		stainless steel 17-4 PH (1.4548)	
Sealing		potted	
Protection according DIN 40.050		IP 67	

Dimensions

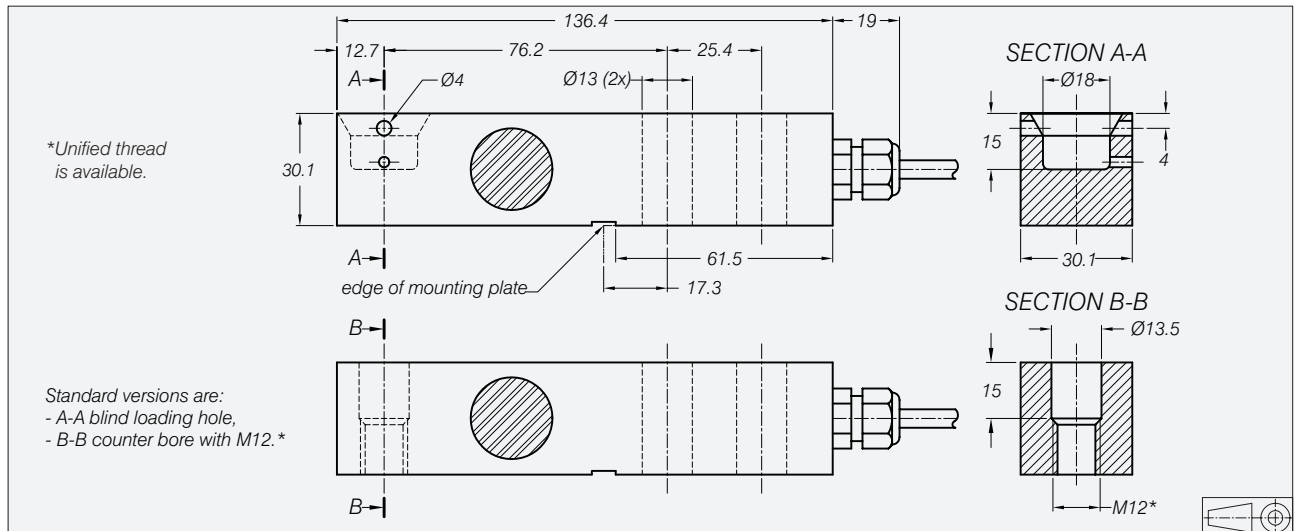

Note:

- Mounting bolts for 500 lb to 2500 lb: M12 8.8/torque 90 Nm; for 5000 lb: M12 12.9/torque 170 Nm.

Wiring

- The load cell is provided with a shielded, 4 conductor cable.
- Cable length: 3 m.
- Cable diameter: 5 mm.
- The shield is floating.

